

Hyperline FX

PTFE LINED SMOOTH BORE FLEXIBLE HOSE



- SMOOTH BORE
- VERY FLEXIBLE
- CHEMICAL RESISTANT
- TEMPERATURE RESISTANT

CONTENTS

Front Cover	Page 1
Contents	Page 2
PTFE - The Optimum Choice For Hyperline Hose Linings	Page 3
Hyperline FX Hose and Hose Grades	Page 4
Hyperline FX Hose Specifications and Properties	Page 5
Hyperline FX Hose Cover Options and Applications	Page 6
Supply Options- Hyperline FX Hose Assemblies and Pre-Cut Lengths	Page 7
Hyperline FX Hose : Special Usage Conditions	Page 8
Hyperline FX Hose - Quality Assurance Certificates and Approvals	Page 9
Correct Hose Configuration	Pages 10 - 12
Conditions of Sale	Page 13
Back Cover	Page 14

PTFE - THE OPTIMUM CHOICE FOR HYPERLINE HOSE LININGS



Section from a PTFE Molecule,
16 Angstrom Units long.

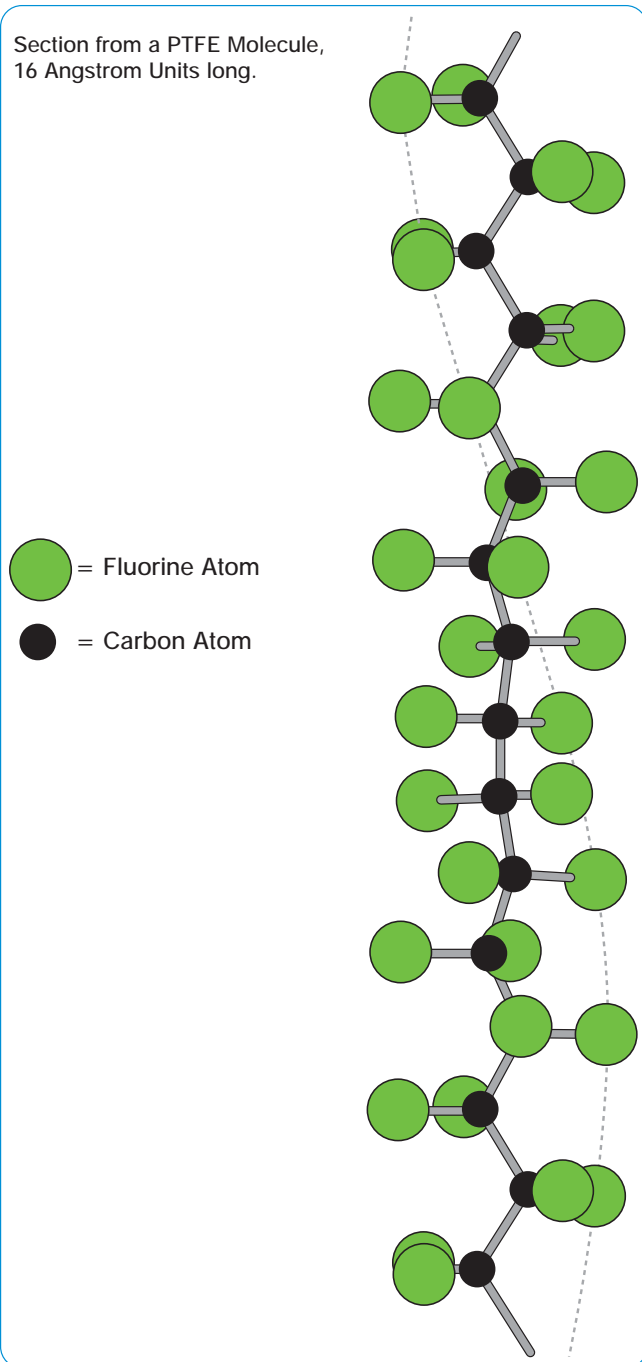

PTFE, or Polytetrafluoroethylene, comprises long-chain molecules of carbon atoms, each linked to two fluorine atoms.

The fluorine atoms provide a helical spiral which surrounds the carbon chain and protects it.

It is this structure which creates the unique properties for which PTFE is well-known.

Excellent Chemical Resistance

PTFE is renowned as the most chemically resistant material known. Only a very few, very unusual substances and conditions can affect it, like Fluorine gas at high temperature and pressure and liquid, boiling sodium metal.

PTFE lined hoses can therefore be used for a wider variety of chemicals than any other hose type, making it the ideal choice for very corrosive chemical applications and multi-product applications.

Non-Stick Surface

The use of PTFE as a surface for cookware products has demonstrated to the world how easily cleanable PTFE surfaces are.

This means that PTFE lined hoses can be purged 100% clean more quickly, easily and reliably than any other type of hose.

Excellent Temperature Range

The cookware application also demonstrates another of PTFE's many attributes - temperature resistance. PTFE itself can be used as a hose liner at temperatures from -150°C up to $+260^{\circ}\text{C}$, dependent upon the hose design and the application conditions.

This is the widest temperature range of any rubber or plastic hose lining material.

Hose Design

The only issue with PTFE as a hose lining material is the best way it can be integrated in to the hose design. This is where Aflex Hose have a proven record of success over the last 30 years.

HYPERLINE FX HOSE

There is a fundamental problem with larger sizes of standard, smooth bore PTFE hose products - as the hose size increases above 1/4", so smooth bore PTFE lined hose become significantly less flexible, and more easily kinked.

One solution is to use a conventional convoluted PTFE lined hose, but the internal convolutions make the hose difficult to assemble, and reduces fluid flow rates due to turbulent flow.

Hyperline FX is a new and revolutionary solution to all these problems, providing a unique and patented hose liner design which is flexible in the larger bore sizes, yet which retains a smooth bore.

The advantage of a smooth bore as compared with a convoluted bore is that it is easy clean, and does not create "turbulent flow", which drastically reduces fluid flow rates.

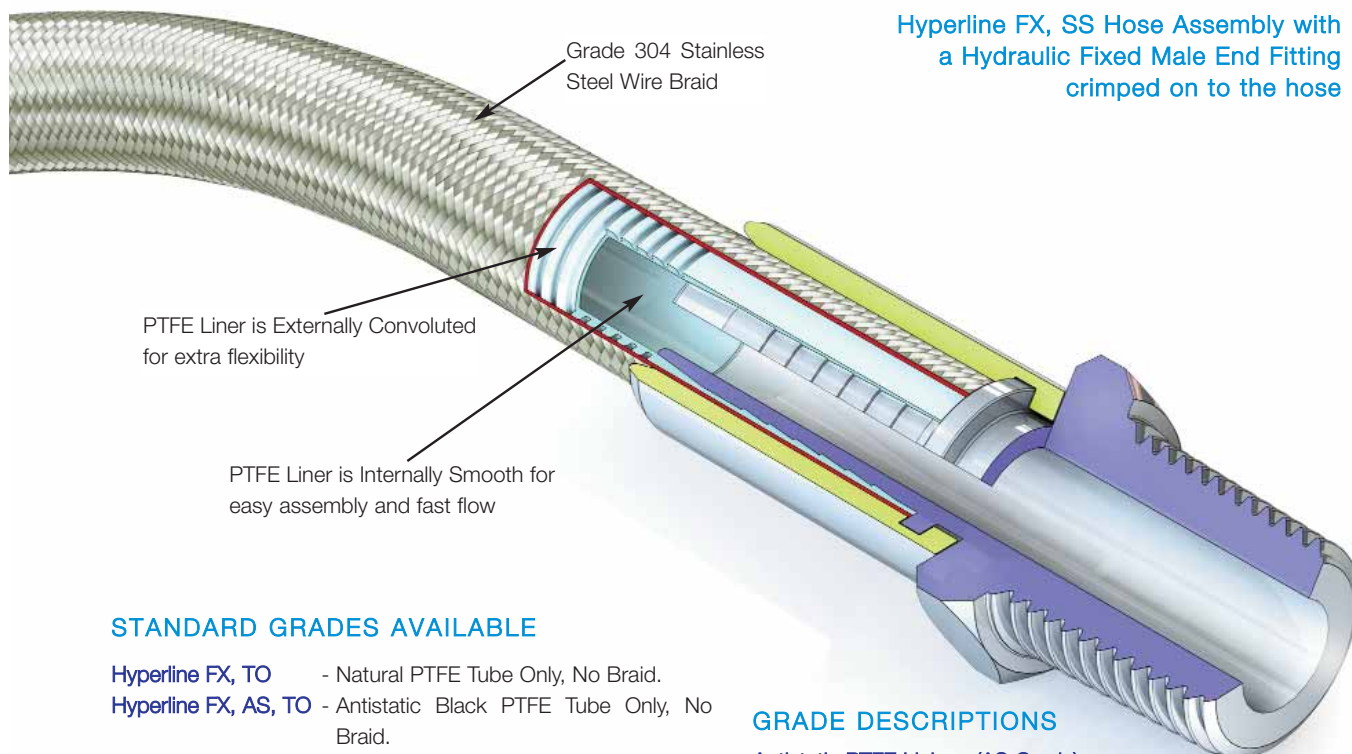

STANDARD GRADES AVAILABLE

- Hyperline FX, TO** - Natural PTFE Tube Only, No Braid.
- Hyperline FX, AS, TO** - Antistatic Black PTFE Tube Only, No Braid.
- Hyperline FX, SS** - Natural PTFE Tube external AISI 304 Stainless Steel Wire Braid.
- Hyperline FX, AS, SS** - Antistatic Black PTFE Tube, external AISI 304 Stainless Steel Wire Braid.
- Hyperline FX, AM** - Natural PTFE Tube, Black Aramid Fibre Braid.
- Hyperline FX, AS, AM** - Antistatic Black PTFE Tube, Black Aramid Fibre Braid.



GRADE DESCRIPTIONS

Antistatic PTFE Linings (AS Grade)

When electrically resistive fluids like solvents and fuels, or multiphase mixtures are passed through natural PTFE hose at high flow rates, a static charge build up occurs on the inner wall of the PTFE liner, which eventually discharges to the nearest earth creating a leak path through the liner.

Antistatic PTFE includes a small quantity of a special carbon black which ensures safe static charge dissipation, in accordance with International Standards.

Stainless Steel Wire Braid (SS Grades)

The braid protects the PTFE liner tube against internal pressure and mechanical abuse.

Aramid Fibre Braid (AM Grades)

The aramid fibre is "Technora", a higher specification fibre than Kevlar, with excellent temperature, tensile and abrasion resistant properties.

For applications requiring minimum weight for maximum pressure reinforcement.

HYPERLINE FX HOSE : SPECIFICATIONS AND PROPERTIES



SPECIFICATIONS FOR HYPERLINE FX HOSE GRADES

Note: Specifications listed below are for non-AS Grades. For AS Grades the specifications are all the same, except that "AS" is added to the Grade Reference, and the Part Number reads "-110-" in place of "-100-".

Nominal Hose Size	*Actual Hose Bore Size		Hose Grade	Outside Diameter of Tube or Braid		Minimum Bend Radius		Maximum Working Pressure (MWP)		Weight per Unit Length		Hose Part Number
	in	mm		in	mm	in	mm	in	Bar	psi	Kg/mtr	
1/4	6.8	0.270	TO	9.0	0.354	38	1 1/2	4	60	.041	.027	92-100-04
			SS	9.6	0.378	19	3/4	88	1280	.092	.062	92-100-04-01-02
			AM	9.6	0.378	38	1 1/2	62	900	.056	.038	92-100-04-01-55-01
5/16	7.9	0.312	TO	10.0	0.394	38	1 1/2	4	60	.056	.037	92-100-05
			SS	10.6	0.420	19	3/4	84	1220	.126	.084	92-100-05-01-02
			AM	10.6	0.420	38	1 1/2	59	850	.075	.050	92-100-05-01-55-01
3/8	10.0	0.394	TO	12.5	0.492	50	2	4	60	.070	.047	92-100-06
			SS	13.5	0.534	25	1	80	1160	.160	.107	92-100-06-01-02
			AM	13.5	0.534	50	2	56	810	.100	.067	92-100-06-01-55-01
1/2	13.6	0.536	TO	16.2	0.640	76	3	4	58	.110	.074	92-100-08
			SS	17.5	0.690	38	1 1/2	60	870	.225	.151	92-100-08-01-02
			AM	17.5	0.690	76	3	42	600	.140	.094	92-100-08-01-55-01
5/8	16.7	0.658	TO	20.0	0.787	100	4	3	44	.161	.108	92-100-10
			SS	21.4	0.843	50	2	50	730	.336	.226	92-100-10-01-02
			AM	21.4	0.843	100	4	35	510	.204	.137	92-100-10-01-55-01
3/4	19.8	0.780	TO	23.2	0.913	126	5	3	44	.179	.120	92-100-12
			SS	24.2	0.953	63	2 1/2	42	610	.383	.257	92-100-12-01-02
			AM	24.2	0.953	126	5	29	430	.236	.158	92-100-12-01-55-01
1	26.4	1.040	TO	30.3	1.193	150	6	2	29	.268	.180	92-100-16
			SS	31.7	1.250	75	3	40	580	.540	.362	92-100-16-01-02
			AM	31.7	1.250	150	6	28	400	.354	.237	92-100-16-01-55-01

*Hydraulic Bore Size - The actual bore sizes of Hyperline FX hose are slightly larger than the nominal size, to allow the insertion and assembly of standard Hydraulic Fittings, using ferrules supplied by Aflex Hose (see page 7).

PROPERTIES

Temperatures and Pressures :

- **Hyperline FX, SS Grades** - The MWP listed above should be reduced by 1% for each 1°C above 160°C (1% for each 1.8°F above 320°F) up to a maximum of 260°C (500°F).
- **Hyperline FX, AM Grades** - The MWP listed above should be reduced by 1% for each 1°C above 130°C (1% for each 1.8°F above 266°F) up to a maximum of 180°C (356°F).

Vacuum Resistance :

Hyperline FX, SS Grades are fully vacuum resistant up to 130°C (266°F).

Excellent Flow Rates :

Compared with conventional convoluted hose designs, Hyperline FX has excellent flow rates due to the smooth bore, which prevents the turbulent fluid flow which occurs in convoluted hose products.

Reduced Diffusion Rates :

Hyperline FX is much more resistant to diffusion of liquids or gases than other PTFE hose products, due to its highly compressed, non-porous PTFE matrix. Hyperline FX has been successfully tested to SAE J1737 for resistance to automotive fuel diffusion.

Non-Stick Internal Surface :

Hyperline FX hose has a smooth bore, non-stick liner which is effectively "self-cleaning", and which resists material build-up inside the hose which may cause bore constriction.

HYPERLINE FX HOSE COVER OPTIONS AND APPLICATIONS

ALTERNATIVE DESIGN OPTIONS - HOSE COVERS

For certain applications, it is an advantage to have a flexible plastic or rubber outer cover extruded on to the hose. The cover provides protection for the braid, as well as being easy to clean, and can be printed with a continuous text line.

Covered hose is, however, only available to special order, so price and availability are very dependent upon quantities required.

Options are:

Flexible PVC (+80°C/+158°F Max.) in transparent or a wide variety of solid or translucent colours.

Nylon 11 (+120°C/+250°F Max.) in natural, semi-transparent or black.

Sarlink, Hytrel, Polyurethane and others may also be available.

EPDM Rubber (+140°C/284°F Max) in Blue or (antistatic) Black.

Silicone Rubber, platinum cured (+200°C/392°F Max.) in natural (semi-transparent) or White.

Other rubbers may also be available.



APPLICATIONS FOR HYPERLINE HOSE

- Automotive and Motorsport : replacing conventional PTFE hoses in ESP systems, fuel systems, braking systems and oil lines.
- Refrigeration : refrigerant feed lines to freezer plates, where the high resistance to permeation, together with the flexibility and chemical resistance, are primary advantages.
- Steam and Gas Lines : where the smooth bore ensures non-turbulent gas flow, leading to noise free operation at higher flow rates, and longer service life.
- Industrial applications in general where the ease of assembly to end fittings together with the higher flow rates, chemical and temperature resistance and resistance to permeation make Hyperline FX the optimum choice.



SUPPLY OPTIONS - HYPERLINE FX HOSE ASSEMBLIES AND PRE-CUT LENGTHS



SUPPLY OPTIONS :

Hyperline FX hose can either be supplied as made up and crimped hose assemblies, or as loose hose for customers to assemble themselves, using ferrules supplied by Aflex Hose, and standard hydraulic end fittings, which can also be supplied by Aflex Hose if required.

Easier Assembly : Hyperline FX is very flexible, and is designed to replace conventional flexible tape wrapped convoluted or autoconvoluted PTFE hoses in application where **faster, cleaner fluid flow or ease of assembly** is paramount. SS or MS ferrules and crimp diameters can be supplied to suit any conventional hydraulic hose tail end fittings.

Problems associated with assembling fittings to convoluted hoses, such as leakages, the need for special or sleeved spigots, the need to de-convolute etc. disappear - Hyperline FX is literally as easy to assemble as any smooth bore hose.

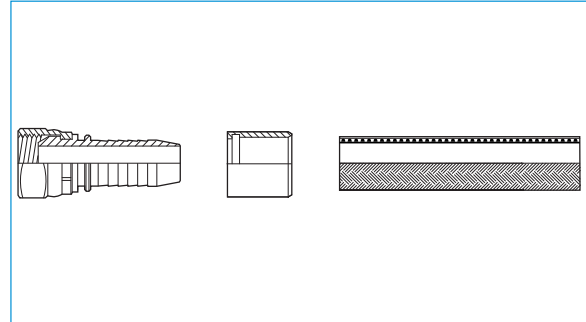

Assembly instructions :

- (1). Cut the hose to the desired length using a cut off machine with a high tensile steel blade, allowing for the length of the end fittings.
- (2). Push the ferrule onto the hose (chamfered end first) and insert the fitting and push into the hose until it meets the collar on the fitting. Align the ferrule over the collar.
- (3). Place the assembly into the swaging machine and swage down the ferrule to the recommended swage dimension as given in Aflex Document AS-42. Check using a vernier or micrometer.

To find AS-42 and the current swage diameters, consult the Aflex Hose I-Bay system. To obtain the I-Bay address, please contact Aflex Hose.

Pressure Testing Instructions :

All self-assembled hose assemblies must be pressure tested to 1.5 x MWP before end use.

Ferrules to Suit :

Hose Size	Ferrule Part Number*
1/4	01-170-04-04-(*03 or 04)
3/8	01-170-06-06-(*03 or 04)
1/2	01-170-08-08-(*03 or 04)
5/8	01-170-10-10-(*03 or 04)
3/4	01-170-12-12-(*03 or 04)
1	01-170-16-16-(*03 or 04)

*Note: Ferrule Part Numbers end in -03 for Stainless Steel (Grade 303 or 304), and -04 for Mild Steel (Zinc Plated).

HYPERLINE FX HOSE - CUT LENGTHS WITH NON-FLARED ENDS

Aflex Hose are also able to supply Hyperline Hose in ready-to-assemble pre-cut lengths, with the braid wire at the ends annealed and cut so the cut ends do not flare out. This makes it easier to slide ferrules on to the hose ends during assembly.

This can be applied to all sizes of Hyperline FX hoses for minimum quantities of 500+ lengths. Minimum cut length 60mm (2³/₈"), lengths cut to an accuracy of + or - 1.5mm (1/16").



HYPERLINE FX HOSE : SPECIAL USAGE CONDITIONS

PTFE Hose-Use with Alkali Metals, Halogens and Halogen containing Chemicals

PTFE hose liners react chemically with Fluorine, Chlorine Trifluoride and molten Alkali Metals.

When PTFE lined hose is used to carry Chlorine or Bromine, either as gasses or fluids, they will diffuse into and through the PTFE liner wall thickness. Trace quantities will then combine with atmospheric moisture to corrode any braid/rubber outer coverings.

Heavily halogenated chemicals, like Hydrogen Fluoride, Hydrogen Chloride, Phosgene (Carbonyl Chloride) Carbon Tetrachloride and other organic chemicals with a high halogen content can also be absorbed and transmitted through the PTFE liner tube.

Other “Penetrating” Fluids and Gases

Sulphur Trioxide, Methyl Methacrylate, Caprolactam and Glacial Acetic Acid are some other chemicals which can be absorbed and transmitted through the PTFE liner tube wall.

Generally, however, as a hydrophobic (non-wetting) material, PTFE is very resistant to the absorption of chemicals. In some cases, PTFE has superior resistance to diffusion, for example to the diffusion of automotive fuels, in comparison with all other plastics and rubbers.

Gas/Fluid Cycling

There are some applications where the fluid passing through the hose turns into a gas, then back into a fluid, then into a gas etc, in a cyclic sequence.

This is normally associated with changes in temperature and/or pressure. For complex reasons these conditions are extremely damaging to the hose liner, whatever material it is made from.

For example, hoses are sometimes used to pass steam, water, steam etc into rubber moulding presses, in order to heat the mould, then rapidly cool it before reheating in the next cycle. Hoses of all types fail rapidly in such an application and PTFE lined hoses are no exception.

Please contact Aflex Hose for further information if these conditions apply.

Connecting Assemblies for Use in Applications

The lengths of hose assemblies and their configuration in use when connected into the application must always be in accordance with the Hose Configuration information at the end of this product literature.

When being connected for use in applications, the end fittings on hose assemblies must be connected to correct mating parts in the correct way, using the correct tools, spanners, clamps, nuts and bolts etc. The connections must be sufficiently tightened to ensure that the joint is leak free but not be over tightened as this can damage the sealing surfaces.

In applications involving the transfer through the hose of expensive or dangerous fluids or gases, the hoses and connections must be pressure tested in situ before being put in to service. This should be done with some harmless media to 1½ times the maximum working pressure of the hose assembly, as stated in the product literature.

If in doubt please contact Aflex Hose for advice.

Special Applications

Aflex Hose PTFE lined hose products are not rated as suitable for use in the following, special applications:

All Radioactive Applications involving high energy radiation, including Gamma radiation (degrades PTFE)

All Medical Implantation Applications.

All Aerospace Applications.

HYPERLINE FX HOSE : QUALITY ASSURANCE CERTIFICATES AND APPROVALS

Hyperline FX and Quality Assurance, Certification and Approvals

BS EN ISO 9001:2008

Aflex products are all manufactured in accordance with BS EN ISO 9001: 2008 Quality Management Systems independently assessed and registered by National Quality Assurance Limited (NQA).

FDA

The Materials used to manufacture the natural PTFE Tube liner conforms to FDA 21 CFR 177.1550, and the antistatic PTFE liner conforms to FDA 21 CFR 178.3297.

3-A Sanitary Standards

The PTFE used in the liner is manufactured solely from materials which meet the requirements of the 3-A Sanitary Standards.

Automotive Fuel Hose - SAE J1737

Tested and approved for automotive fuel hose use in accordance with SAE J1737.

CE Marking (Europe only)

Aflex has been assessed by Zurich Engineering and found to comply with the Pressure Equipment Directive 97/23/EC (European Community) Conformity Assessment Module D1, approved to CE Mark applicable hose products, accompanied by a Hose Usage Data Sheet, and a Declaration of Conformity.

Attestations of Conformity to ATEX Directive 94/9/EC (Potentially Explosive Atmospheres)

Available for hose and assemblies for components used in Gas Zones 1 & 2 and Dust Zones 21 & 22, when applicable.

Material Certification to EN10204

Available for all the hose or hose assembly components.

Certificates of Conformity to BS EN ISO/IEC 17050

Are available for all products.

HOSE CONFIGURATION & LENGTH CALCULATIONS

- for BEND RADIUS

Hose Configuration Requirements

Hose Assemblies are usually connected at both ends in service. They may then either remain in a fixed, or static configuration or in a flexing, or dynamic configuration.

Whether static or dynamic, the First Rule concerning the configuration of the hose is that the bend radius of the hose must never be less than the Minimum Bend Radius (MBR) for the hose as listed in the relevant hose brochure.

The most common situation when this is likely to occur is when the hose is flexed at the end fitting, with stress being applied to the hose at an angle to the axis of the end fitting. Typically, this happens either because the length of the hose is too short, or because the weight of the hose plus contents creates a stress at an angle to the end fitting.

The Second Rule, therefore, if possible, is to design the configuration to ensure that any flexing in the hose takes place away from the end fittings.

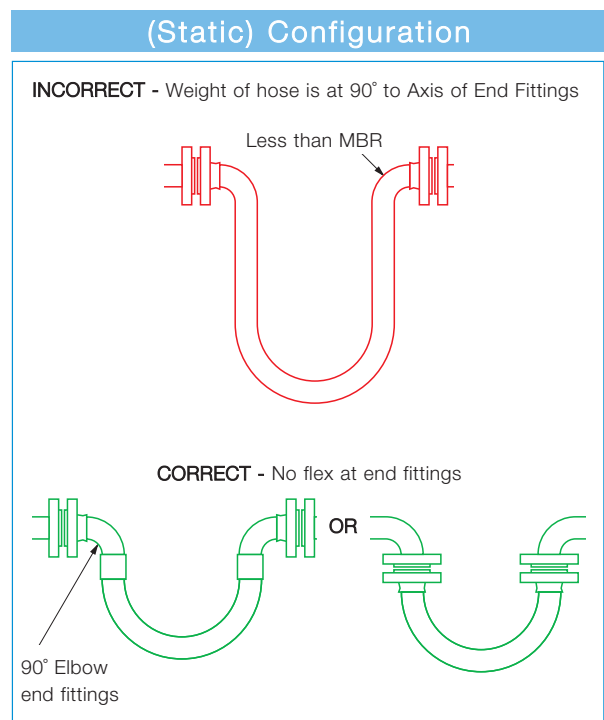
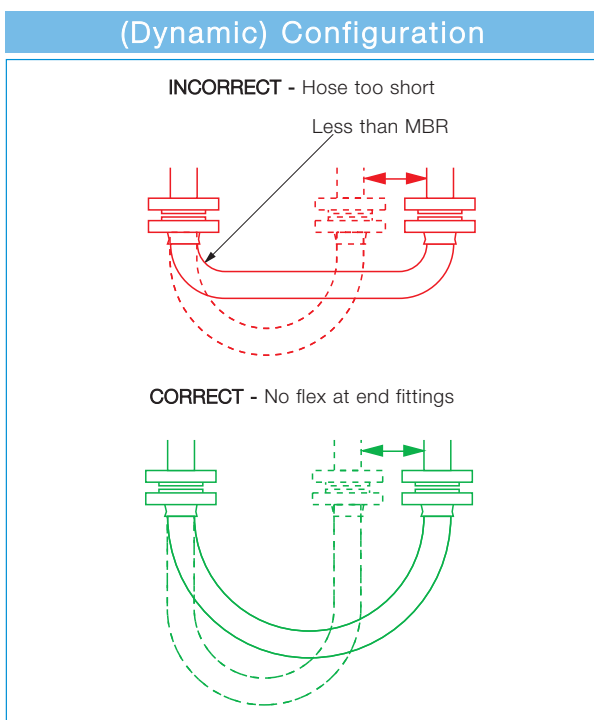

HOSE CONFIGURATION & LENGTH CALCULATIONS

- for ABRASION & TORQUE



The Third Rule is that the hose configuration should always be designed, and supported where necessary, to avoid any possibility of external abrasion.

In some cases, the length, configuration and angle of the hose can be designed to avoid abrasion. In others, static or moving support frames or support wheels are required.

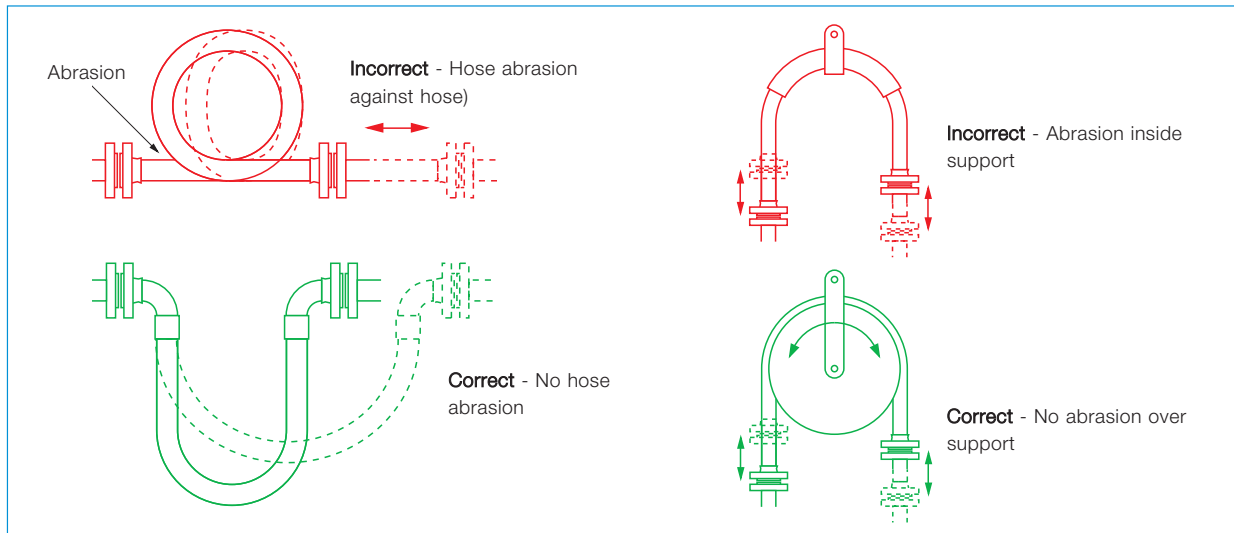

The Fourth Rule is that the hose must not be subjected to torque, either during connection, or as a result of the flexing cycle.

Torque (twist) in the hose can be applied during connection if the hose is accidentally twisted, or if the second end being connected is a screwed connection, and the hose is subjected to torque during final tightening.

In a flexing application, if any flexing cycle of the hose occurs in 3 dimensions instead of 2, then torque will also occur:

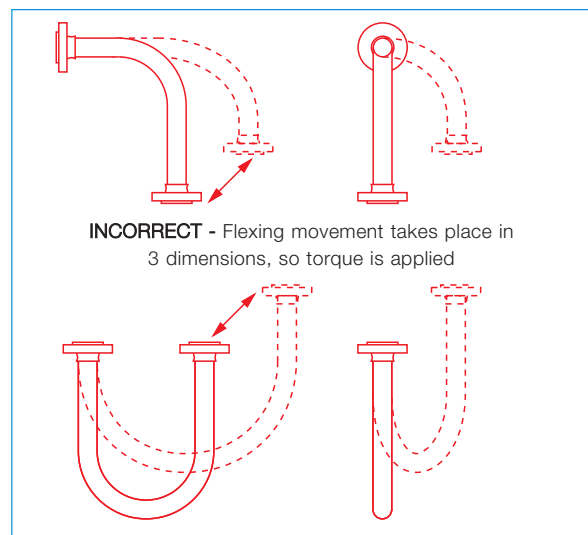
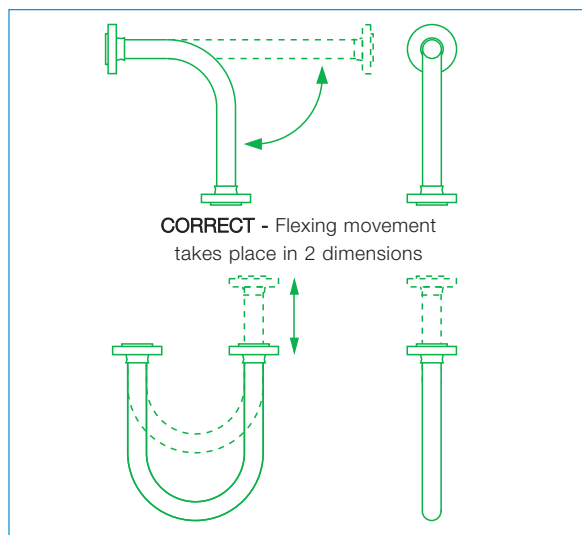

Both Pharmaline and Pharmalex hose have good resistance to a small level of torque, much better resistance than rubber or SS hose types, but it is still the best practice to take whatever steps are necessary to eliminate torque. If in doubt, consult Aflex Hose.

HOSE CONFIGURATION & LENGTH CALCULATIONS

- for LENGTH CALCULATIONS

CALCULATING THE HOSE LENGTH

The formula for calculating the bent section of the hose length around a radius is derived from the basic formula that the circumference of a circle = $2\pi R$, where R = the radius of the circle, and π = a constant, = 3.142.

So, if the hose goes around a 90° bend, which is $\frac{1}{4}$ of a full circumference, and the radius of the bend is R , then the length of the hose around the bend is = $\frac{1}{4} \times 2\pi R$. Or half way round, in a U-shape, = $\frac{1}{2} \times 2\pi R$.

Note :

In calculating the length of a hose assembly, the (non-flexible) length of the end fittings must be added in, also the length of any straight sections of hose, as in the following example:

Example :

To calculate the length for a 2" bore size hose with flange end fittings, to be fitted in a 90° configuration with one leg 400mm long, the other 600mm long.

$$\begin{aligned} \text{Length of Bent Section (yellow)} &= \frac{1}{4} \times 2\pi R \text{ (334)} \\ &= \frac{1}{4} \times 2 \times 3.142 \times 334 = \mathbf{525\text{mm}} \end{aligned}$$

$$\begin{aligned} \text{Length of top, Straight Section, including the top end fitting length} \\ &= 600 - 334 = \mathbf{266\text{mm}} \end{aligned}$$

$$\text{Length of bottom end fitting} = \mathbf{66\text{mm}}$$

$$\text{Total length of Hose Assembly} = 525 + 266 + 66 = \mathbf{857\text{mm}}$$

Things to consider

- A hose will normally take the longest radius available to it to go around a corner, not the MBR! Also - always remember to include the **non-flexible** end fitting lengths.
- In dynamic applications, remember to always calculate the lengths for the most extended configuration during the flexing cycle, not the least extended.
- If the configuration is simply too complex for calculation, then obtain a length of flexible tubing of some kind, mark on paper, or a wall, or floor, or both where the connection points will be relative to each other, scaled down if necessary, then manually run the flexible tubing between them with full radii round bends. Measure the extended length, then scale up if necessary to determine the approximate length of the hose.

If in doubt, consult Aflex Hose.

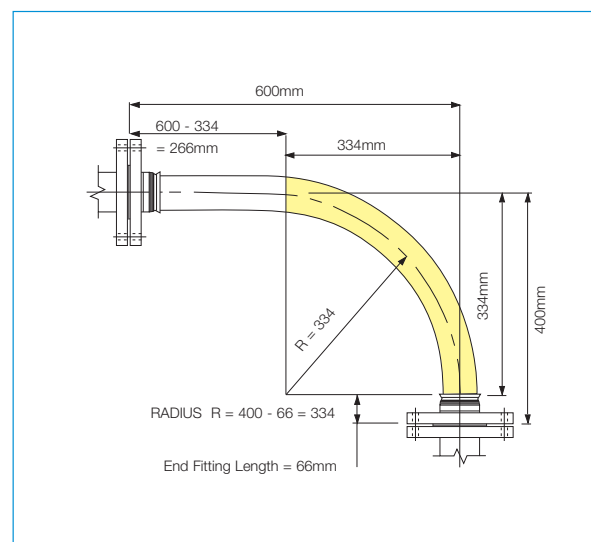
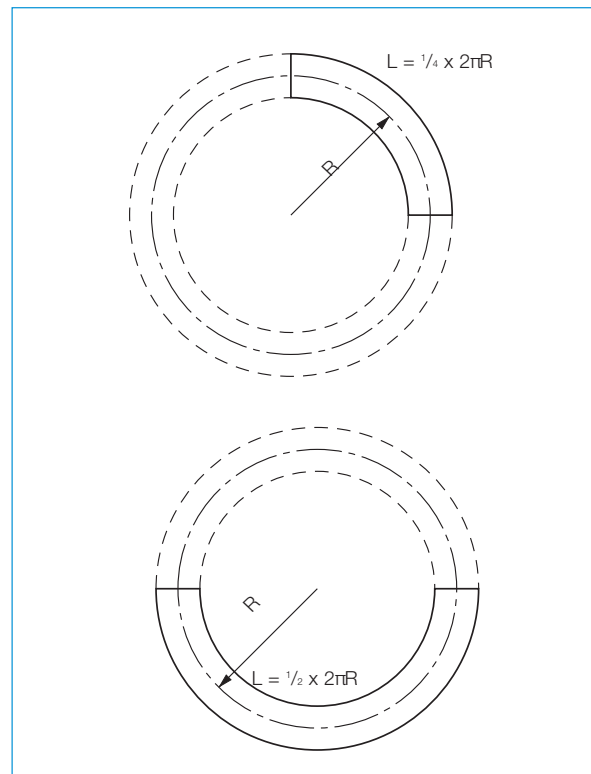

CONDITIONS OF SALE

General

Aflex PTFE hose products have not been designed or tested to be suitable for use in any **Aerospace, Medical Implantation or Radioactive applications** and such use is therefore strictly prohibited unless written approval from Aflex Hose Ltd has been given.

Aflex Hose Ltd will not accept liability for any failures of the Aflex Hose Products which are caused by customers failing to perform their Responsibilities as specified in these Conditions of Sale.

It is the customer's strict Responsibility to review all of the usage limitations given for the hose which he intends to use in an application, to ensure that the application conditions are in compliance with those usage limitations. The usage limitations are specified both on this page, in the [Full Brochures](#) for the relevant products on the Aflex Hose website. Customers must always consult the latest, up to date information, which is only available and downloadable from the Aflex website.

It must be accepted, however, that the usage limitations specified elsewhere in the Hose Product Information and on this page are intended as a guide only, since every possible factor in every type of application cannot possibly be covered. It is therefore the Customer's Responsibility to ensure the design suitability and safety of the products in their intended applications, giving particular consideration to the chemical and electrostatic compatibility of the fluids or gases passing through, the possibility of diffusion of fluid or gases through the PTFE hose lining, the possibility of external corrosive conditions, the types and likelihood of excessive mechanical abuse, such as abrasion (internal or external), crushing, excessive flexing or vibrations etc, and any excessive temperature and/or pressure "pulsing" conditions, all of which may cause premature hose failure. It is also the Customer's Responsibility to consider, and take account of the degree of risk involved in any hose failure, including the provision of adequate protection in the event of any risk to employees or the general public. In applications where any type of hose failure would lead to financial losses if the hose is not replaced immediately, it is the Customer's Responsibility to order and hold in stock spare hose(s) accordingly. It is also the Customer's Responsibility to advise Aflex Hose in writing if there are any special requirements for the hose, including cleaning, or drying, or extra testing requirements which are in addition to normal industrial standards.

If the Customer has any doubts concerning these or any other usage limitation or safety parameters, it is the Customer's Responsibility to consult Aflex Hose Ltd, to request a written response to any queries.

It is the Responsibility of the Customer to ensure that if the product is sold on, or passed on, however many times, that all the necessary information including this page and the Aflex Hose website address are also passed on to the final user, together with a specific requirement that the final user must review the usage limitations in terms of his own application.

Hose Service Life

It is not possible to guarantee a minimum service life for any of the Aflex Hose products which can be applicable for every type of application.

(For example, PTFE lined hose has been used in one application where it was cycled with hot steam, then cold water, also flexed every 17 seconds 24 hours per day, and the customer was very satisfied with a service life of 3 weeks before failure. In other light duty applications carrying pharmaceutical products, however, many Corroflon hoses are still performing satisfactorily after 20 years in service).

Service life predictions or guarantees can only be given in cases where all the relevant information concerning the application is given in writing to Aflex Hose, and Aflex Hose subsequently replies in writing prior to the order being placed.

If such a written undertaking is not sought and given, then Aflex Hose cannot be held liable for any hose product failure which the customer considers to be premature, excepting failures which are due to faulty materials or manufacturing defects.

24 Month Warranty

Aflex Hose Ltd warrants its products to be free from faulty materials or manufacturing defects from the date of the initial sale, for 24 months.

N.B. All ETH Hoses are only warranted for 12 months.

Product Failure

In the event of a product failure, Aflex Hose requests that the product should not be cut up or tampered with, but should be de-contaminated and returned to Aflex Hose, plus a decontamination certificate, for examination and analysis of the fault. The customer should also provide full details in writing of the application conditions under which the hose failed, including Pressure, Vacuum, Temperature, Flexing and any cycling of any of these, also the fluid and gases passing through the hose, and the total time that the hose has been in service. The customer may send his own witness to the examination if required. Aflex Hose will provide a full Non Conformance Report for the customer.

If faulty materials or a manufacturing defect in the hose was responsible for the failure to perform then, the maximum liability to be accepted by Aflex Hose would include the invoice value of the failed hose itself, or the invoice value of the whole customer order if appropriate, also any reasonable costs for removal and replacement of the hose, and costs for packing and despatching the failed hose back to Aflex Hose. Aflex Hose Ltd will not accept liability for any other consequential or financial losses, including, but not limited to loss of profits, loss of products or downtime costs.

Untested Hose for Self Assembly by Customers

Aflex Hose sometimes supplies "loose" hose, without end fittings attached to Self Assembly Customers, who will then cut the hose to length and attach end fittings to make up Hose Assemblies.

Self Assembly Customers must then accept the responsibility to carry out pressure testing of 100% of such assemblies to 1¹/₂ times the Maximum Working Pressure (MWP) if the hose as listed in the Full Product Brochure before supply for end use, to validate both the hose and the end fitting attachment.

When pressure testing hoses with a plastic or rubber outer cover, the cover will mask any signs of leakage for a time. It is therefore recommended that after the Hydrostatic Pressure Test, the hose should be tested at the MWP with air under water for a minimum test period of 5 minutes.

Unless the customer requests, and Aflex Hose confirm that their loose hose is pressure tested before supply, such testing is not normally applied by Aflex Hose, because this testing requirement is satisfied by the Self Assembly Customer during his own testing of the finished Hose Assembly.

The Self Assembly Customer must also accept responsibility for determining and approving the Design Suitability of the hose assemblies for their intended use before supply.

This includes determining and requesting or applying any special tests which may be identified as necessary to ensure suitability for the intended use.

Aflex Hose will only accept liability for its hose products which are assembled by Aflex Approved Self-Assembly Companies if all the hose and fitting components were supplied by Aflex Hose or approved for use by Aflex Hose, and they were assembled and tested in accordance with Aflex Hose's current Manufacturing and Testing Instructions, available to approved Self Assemblers in an I-Bay on the Aflex Hose website.

Untested Hose Assemblies

Aflex Hose is sometimes requested by customers to attach non-standard end fittings to hose assemblies which they supply, and in some cases it is not possible to connect these fittings to the pressure test system. In such cases a Concession not to test is obtained from the Customer, and a label is attached to the hose assembly, warning that it requires pressure testing before use.

Force Majeure

Aflex Hose Ltd shall not be liable for any delay or default in performing in accordance with any Customers' order if the delay or default is caused by conditions beyond its control, including, but not limited to wars, insurrections, strikes, natural disasters or performance failures by Carriers, sub-contractors or other third parties outside the control of Aflex Hose Ltd.

Legal System

These Conditions of Sale are subject to English Law.



**Pışmiş Ticaret Kauçuk Ürünleri, İş Emniyeti ve San. Malz. Adı Kom. Şti.
Faruk Pışmiş ve Ortağı**

Merkez : Persembepazarı Tünel Cd. Kuthan No:38/C Karaköy - İstanbul
Sic.Tic. : 192821 - 140348 Galata V.D. : 730 003 7734
Faruk Pışmiş Galata V.D. 4747 9333 178 - Fadıl Pışmiş Kartal V.D. 4747 0333 450
E-mail : info@pismisticaret.com.tr
Tel : 0 212 293 96 95 - 0 212 243 59 36 - 0 212 292 27 43 - 0 212 249 58 82
Fax : 0 212 245 65 14 - 0 212 292 27 42

www.pismisticaret.com.tr



UK HYPFX/22.09.11.11 Rev